

FDCDD

Fire damper, round, damper blade 25 mm

CE marked in accordance with EN 15650:2010

Tested in accordance with EN 1366- 2

Classified in accordance with EN 13501- 3

LUKA C/ATC 3

Use

The round fire dampers type FDCDD can be used in fire and smoke-separating solid and flexible walls. If they are incorporated in accordance with the instructions, there is a fire resistance of up to 60 minutes depending on how they are built in. The damper is supplied with a fitted mounting frame and Belimo motor. This has a fitting advantage, as it is easier and quicker to fit. The fusible link has to be fitted in the subsequent duct. For the classification list and the corresponding installation instructions, please see the manual on our website. Certified use requires compliance with the installation instructions in the [manual](#).

Characteristics

- Available in dimensions of \varnothing 100 to 315 mm.
- Fitted in the wall in any spindle direction or airflow direction.
- Airtightness class C over the housing in accordance with EN1751 (LUKA C)/ATC3.
- Airtightness class 3 over the damper blade in accordance with EN1751.
- Hygiene certificate in accordance with VDI 6022.

Finish

housing:	galvanised sheet steel
damper blade:	heat-resistant thickness 25 mm
fusible link:	72 °C

Optional (information available on request)

- Galvanised sheet steel with internal and external powder coating.
- Stainless steel EN1.4301/EN1.4401/EN1.4404 (AISI 304/316/316L).
- Stainless steel EN1.4301/EN1.4401/EN1.4404 (AISI 304/316/316L) with internal and external powder coating.
- Motor-operated version with 95 °C fusible link.
- Belimo supply and/or communication module BKN-230-24-MOD.
- Promaseal S white silicone sealant: tube 310 ml (expected use: approx. 3 m/tube with 10x10 mm adhesive layer)

For other versions, please ask our sales department.

Classified in accordance with EN 13501- 3

For a full classification overview with the various sealing methods, we refer to the [manual](#).

Available types

F D C D D - -

- F** fire-resistant
- D** damper
- C** round
- DD** direct drive

- Mounting frame

- O** standard

- Operation

Motor-operated

M24S Belimo 24V

M230S Belimo 230V

M24S-ST Belimo 24V plug-and-play for connection to Belimo supply and/or communication modules

Dimensions

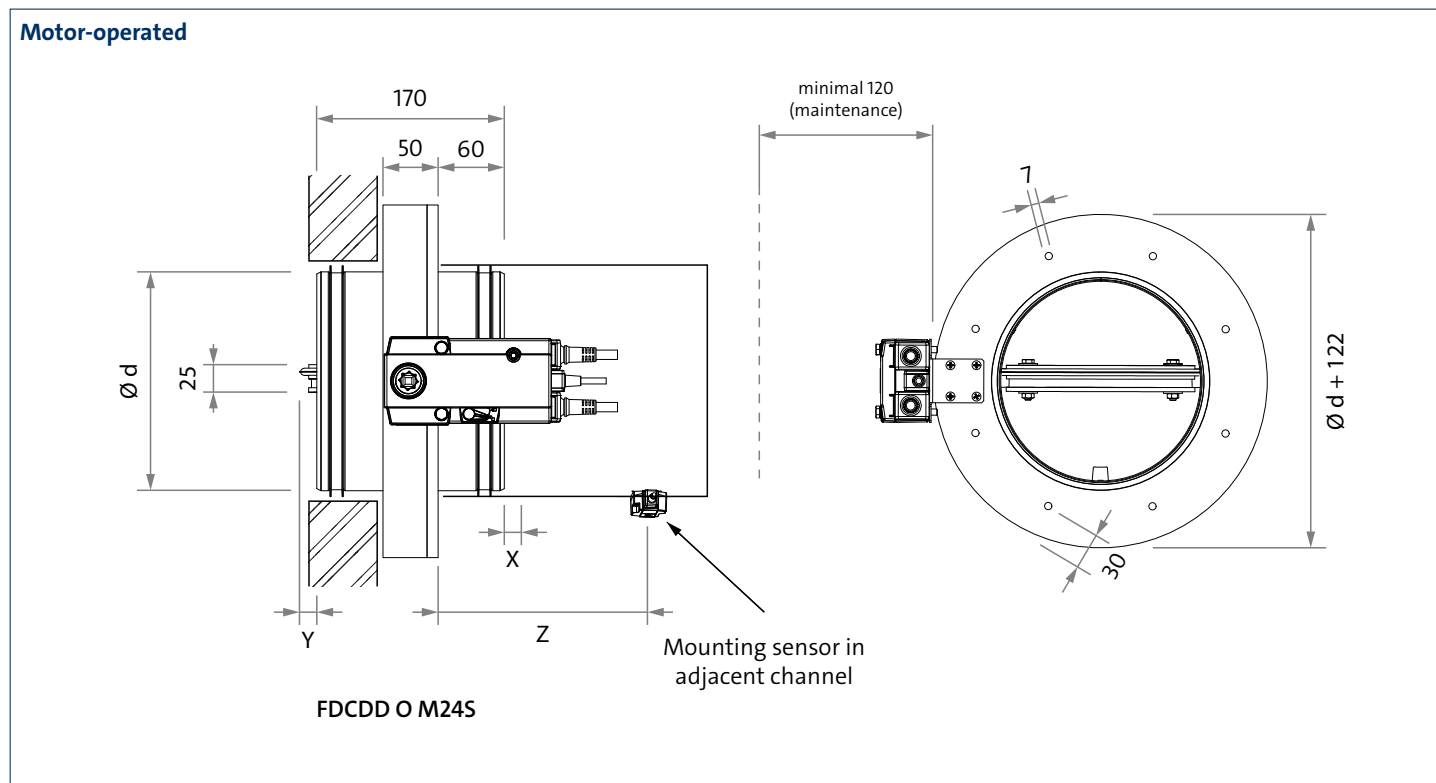

Available dimensions

model/ Dnom	d	free passage in m ²	X	Y	Z	g
100	98	0.005	-	-	90	3.0
125	123	0.0087	-	-	90	3.4
160	158	0.0155	-	-	90	3.9
200	198	0.0256	22	16	100	4.6
250	248	0.0418	38	41	130	5.5
315	313	0.0687	70	74	160	6.9

X, Y = protruding length of the damper blade.

Z = minimum distance from sensor to calcium silicate.

g = weight in kg.

For more specific information about the dimensions, please refer to the [manual](#).

Comments

- The dimensions are in mm.
- Please visit our website to download the [manual](#) and [declaration of performance \(DoP\)](#).

Fitting

The fire damper is fitted, in a closed position, in line with statutory regulations in accordance with the [manual](#).

A clearance of approximately 300 mm is recommended for good access to the servomotor.